

S t r a t a F u r n i t u r e
Addison

ADD 0404

1A Parts in the Arm Box:

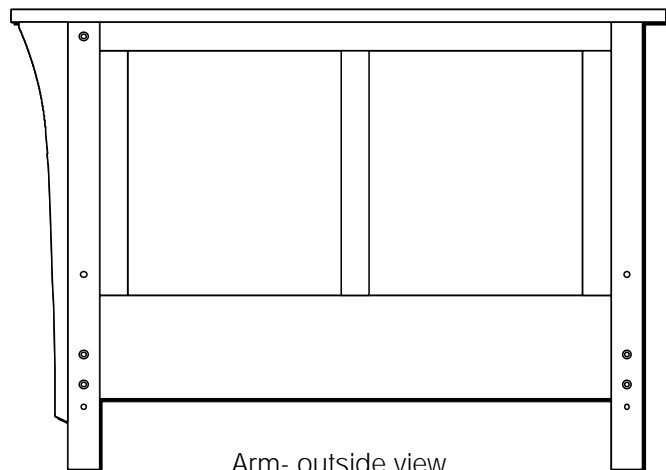

Arm- outside view

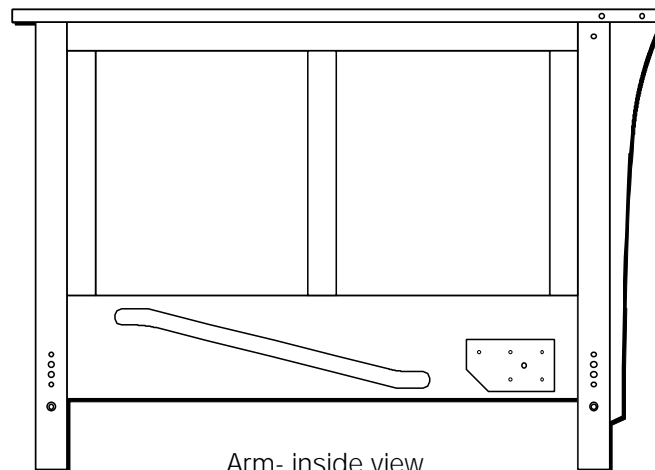

Arm- inside view

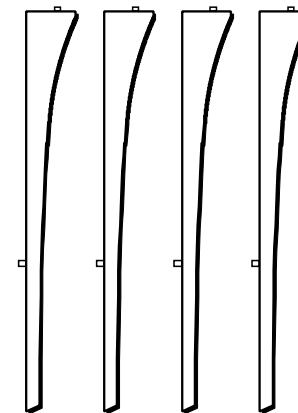

Corbels **x 4**

1B Parts in the Body Box:

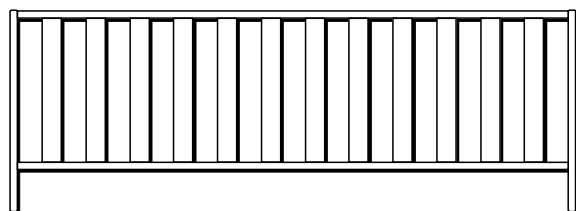

Back Deck **x 1**

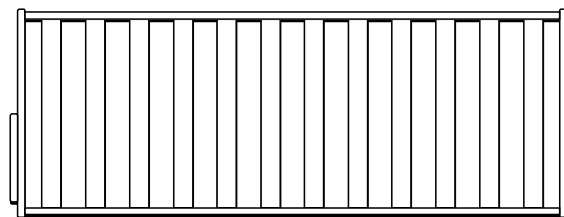

Seat Deck **x 1**
with the Feet attached

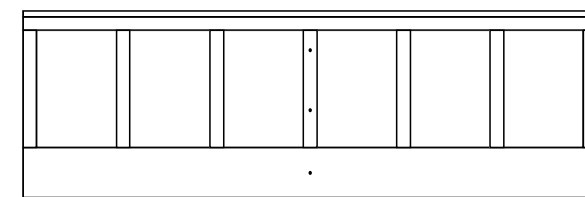

Back Panel **x 1**



Stretcher **x 1**

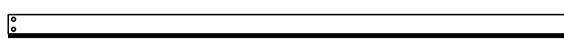

Foot Connector Bar **x 1**



Back Panel Corbel
x 1

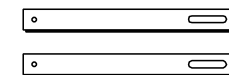

Advance Arms
x 2

S t r a t a F u r n i t u r e
Addison

ADD 0504

2A Hardware in this Box:

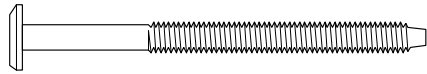

Long Bolts (80mm) **x 10**
For the Stretcher and Back Panel

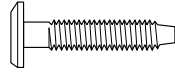

Short Bolts (30mm) **x 2**
*For the Back Panel
 Corbels*

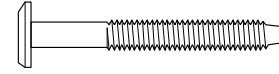

Bolts (50mm) **x 4**
For the Arm Corbels

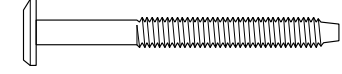

Bolts (60mm) **x 6**
*For the Advance Arms
 and the Foot Connector Bar*

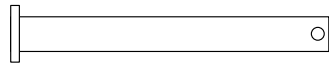

Long Clevis Pins
x 2

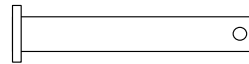

Short Clevis Pins
x 2

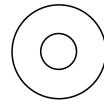

Washers
x 6

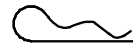

Locking Pins
x 4



Barrel Nuts
x 10



Wooden Dowel
x 4

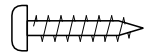

Screw
x 4

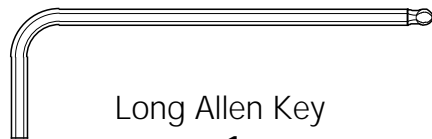

Long Allen Key
x 1



Plastic Runner
x 2



Bungies **x 2**

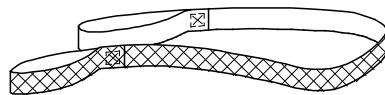

Strap **x 1**



Sleeve **x 2**

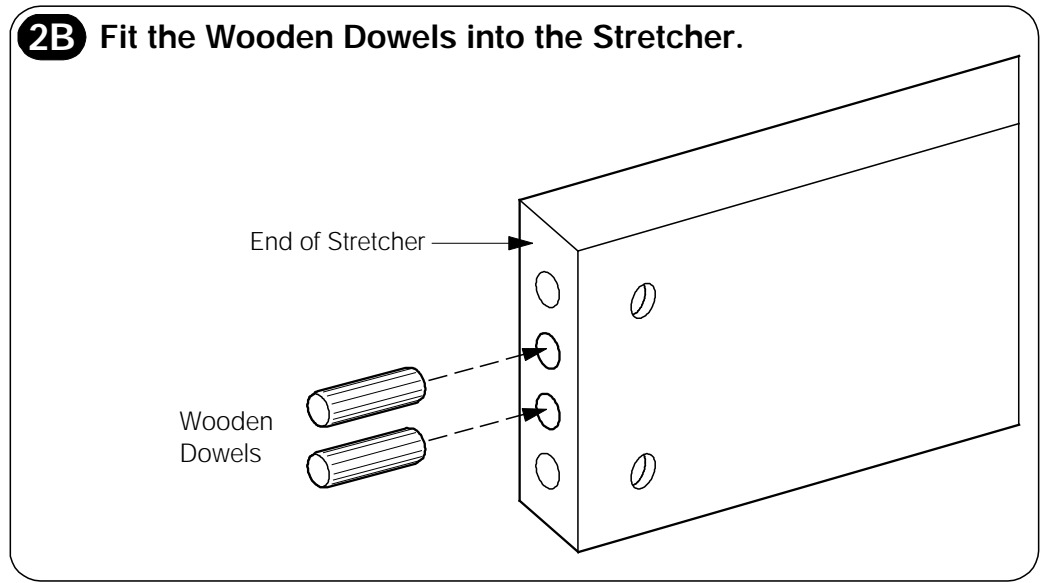

S t r a t a F u r n i t u r e
Addison

ADD 0404

3A Assemble the Back Panel between the Arms.

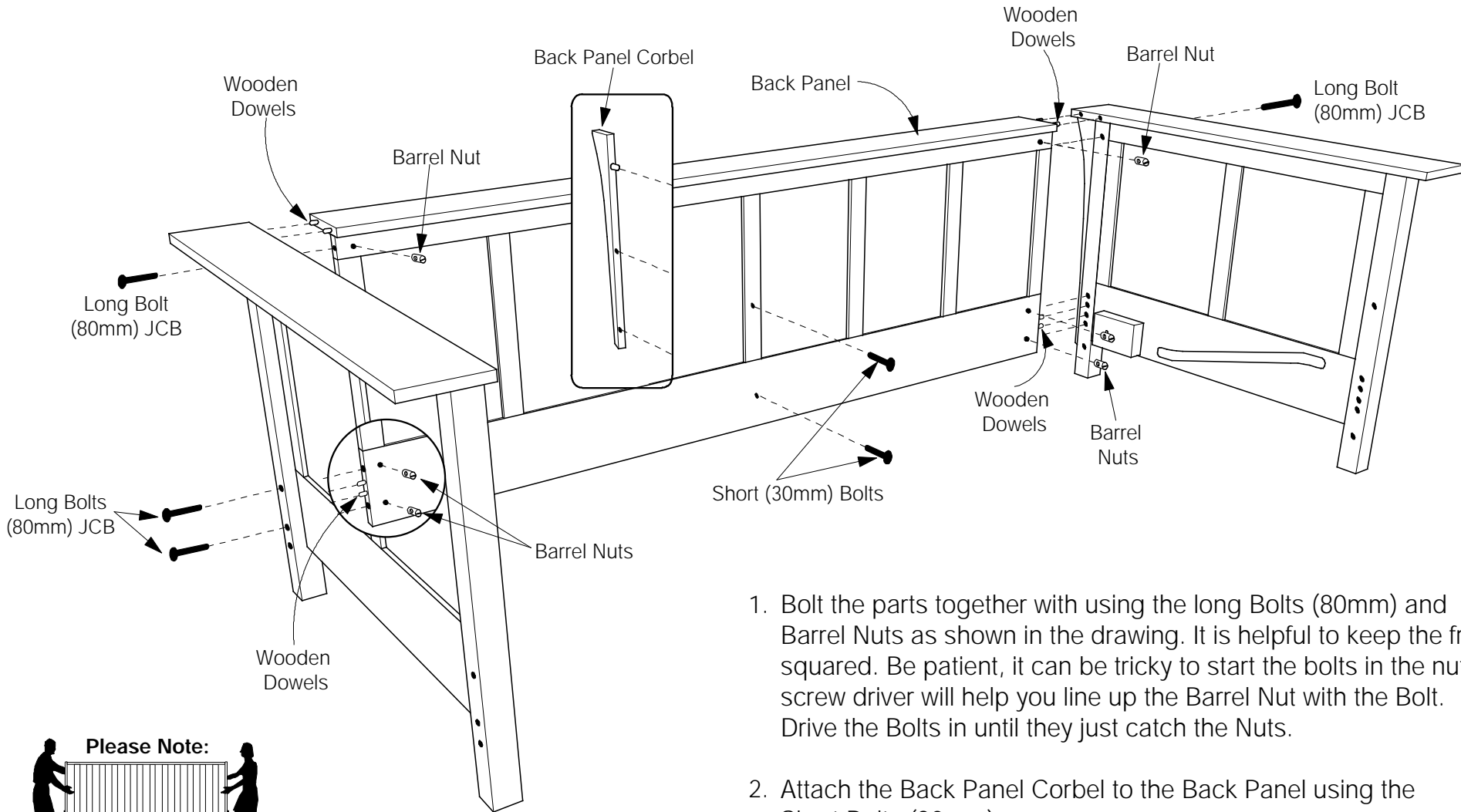

1. Bolt the parts together with using the long Bolts (80mm) and Barrel Nuts as shown in the drawing. It is helpful to keep the frame squared. Be patient, it can be tricky to start the bolts in the nuts - A screw driver will help you line up the Barrel Nut with the Bolt. Drive the Bolts in until they just catch the Nuts.
2. Attach the Back Panel Corbel to the Back Panel using the Short Bolts (30mm).

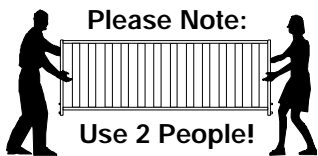

S t r a t a F u r n i t u r e
Addison

ADD 0404

4A Assemble the Stretcher between the Arms.

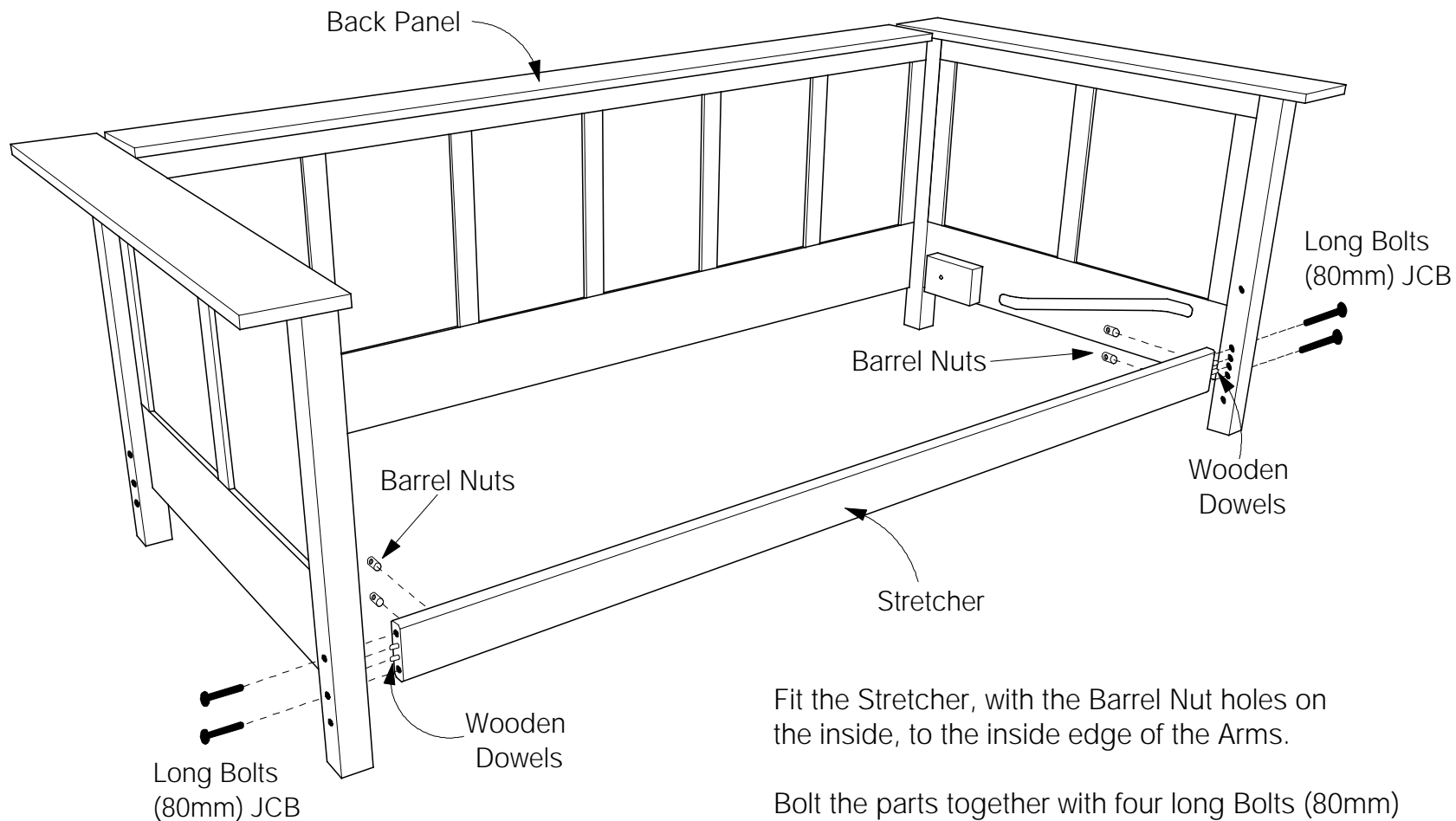

Fit the Stretcher, with the Barrel Nut holes on the inside, to the inside edge of the Arms.

Bolt the parts together with four long Bolts (80mm) and Barrel Nuts.

Drive the Bolts in until they just catch the Nuts.

Strata Furniture
Addison

ADD 0404

5A Join the Seat and Back Deck together.

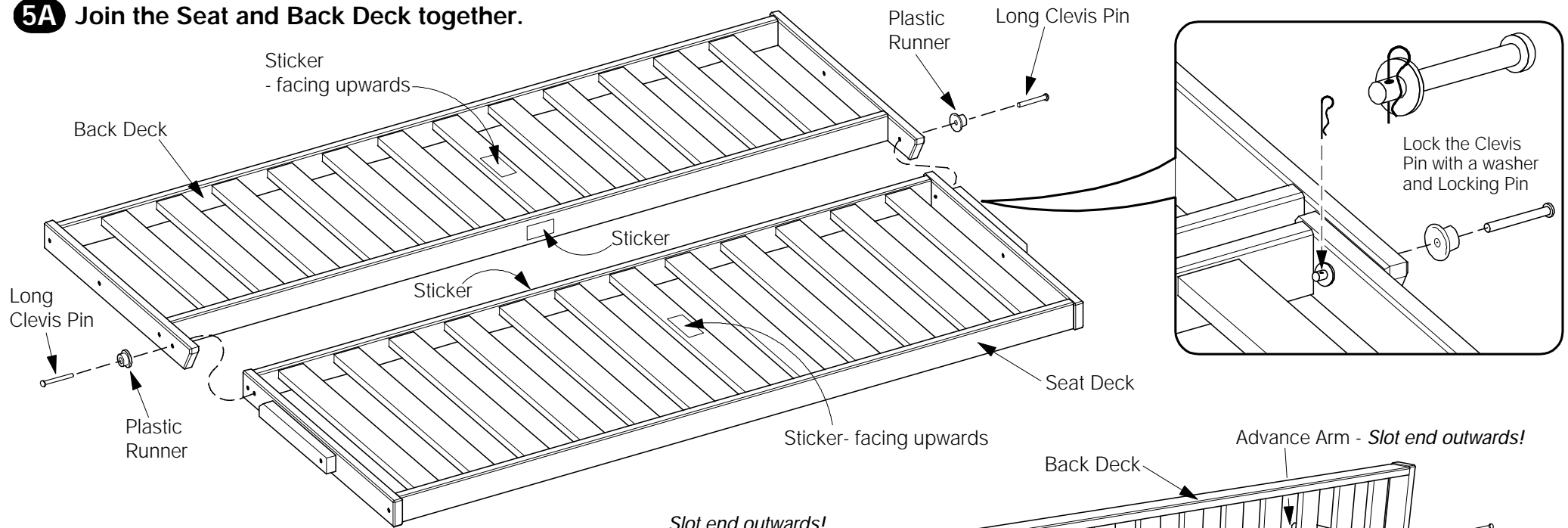

Lay both Decks out flat on the floor with the stickers facing upwards.

The Seat Deck fits inside the Back Deck as shown. Slip the Long Clevis Pin through the small end of the Plastic Runner, through the hole in the Back Deck and the corresponding hole in the Seat Deck. Secure with a Washer and Locking Pin.

5B Fit the Advance Arms to the Back Deck.

Rotate the Back Deck upright. Attach the Advance Arms on the inside using the short Clevis Pins. Secure with a Washer and Locking Pin.

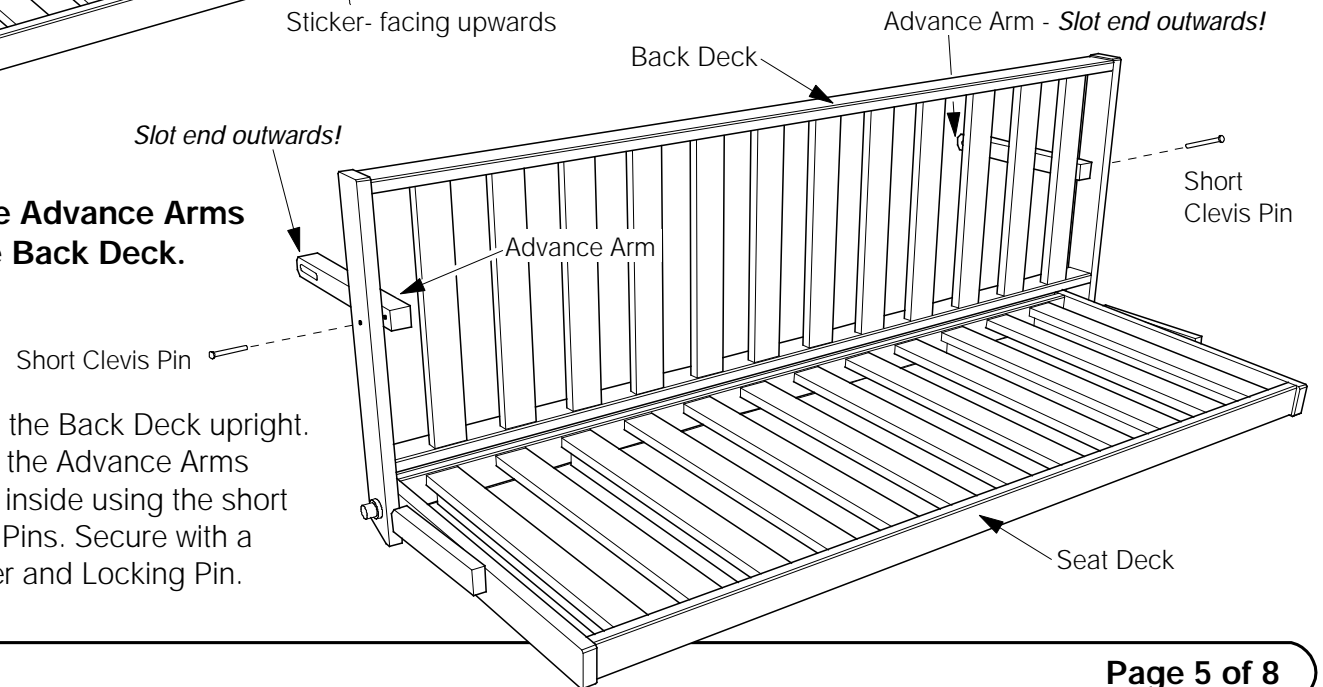

6A Attach the Connector Bar to the Legs.

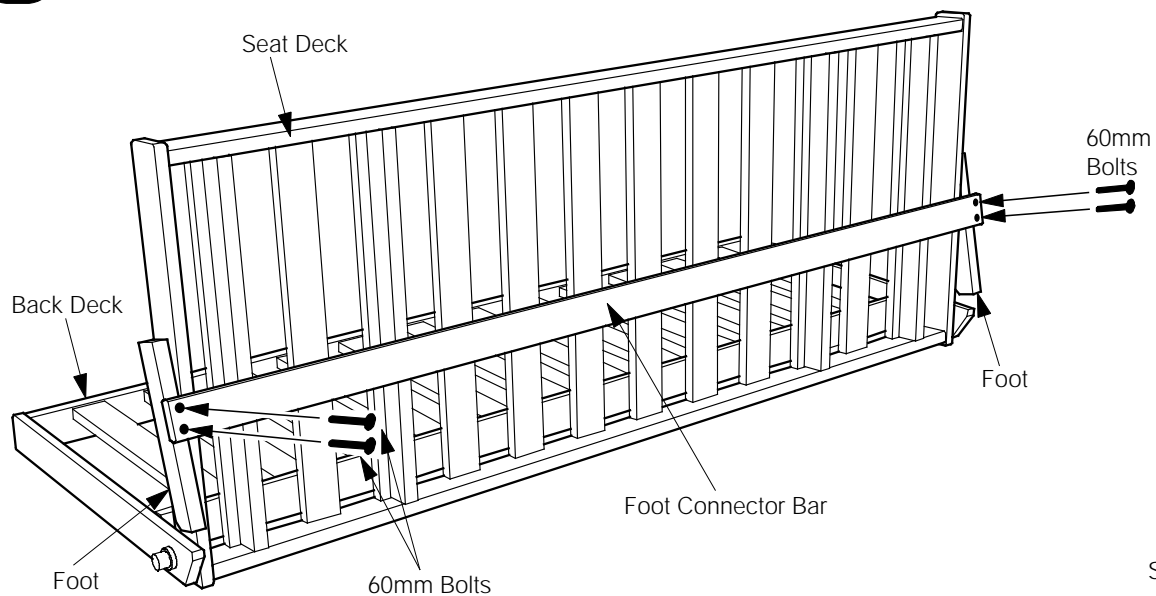

Lift the Seat Deck so it resting on the Back Deck. The feet should be pointing downwards.

Line up the holes between the Connector Bar and the Legs. Make sure the recess for the head of the Bolt is facing outwards.

Use four Bolts (60mm) and bolt it in place.

6B Assemble the Bungies under the Seat Deck.

Screw the Bungies to the side of the two inner rails. Fix the lower end of the Bungie chord first, then stretch the Bungie over the Connector Bar. Fix the top end.

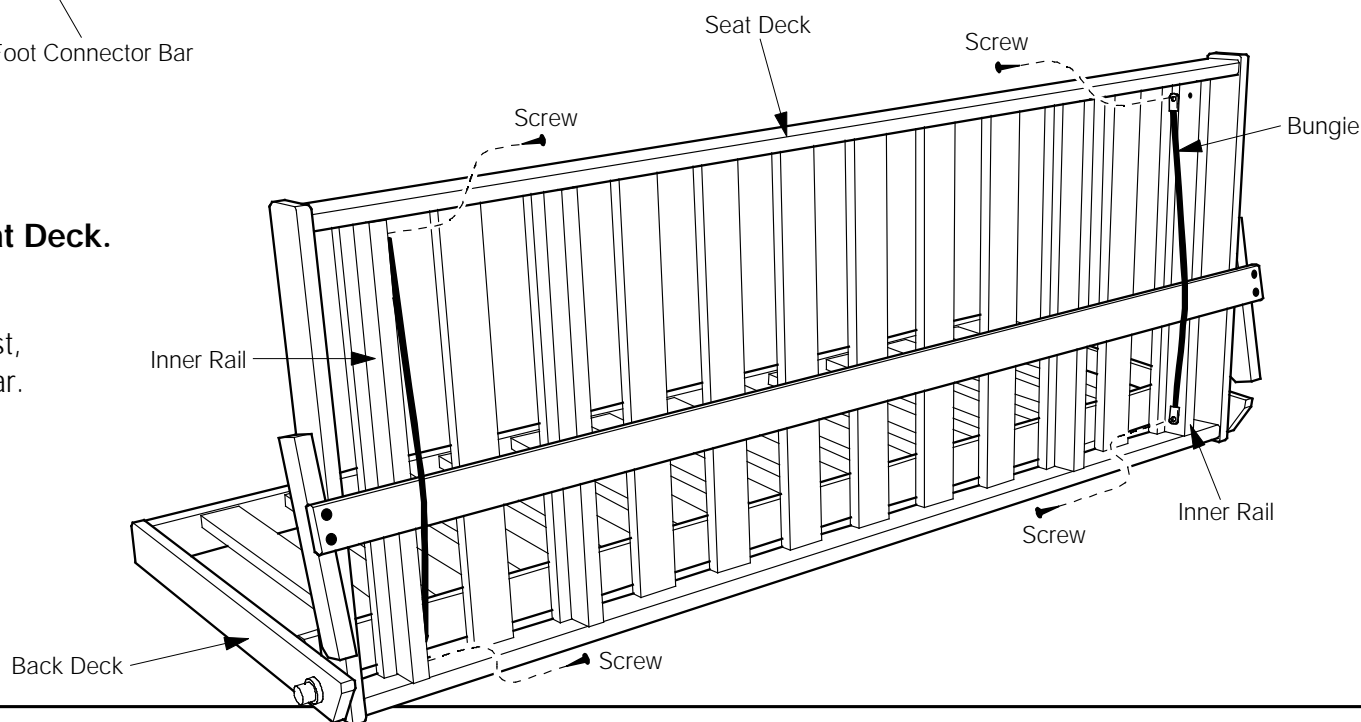

Strata Furniture
Addison

ADD 0404

7A Fit the Seat and Back Decks to the Frame.

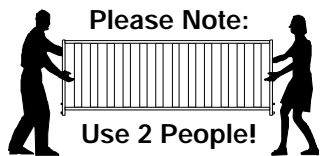
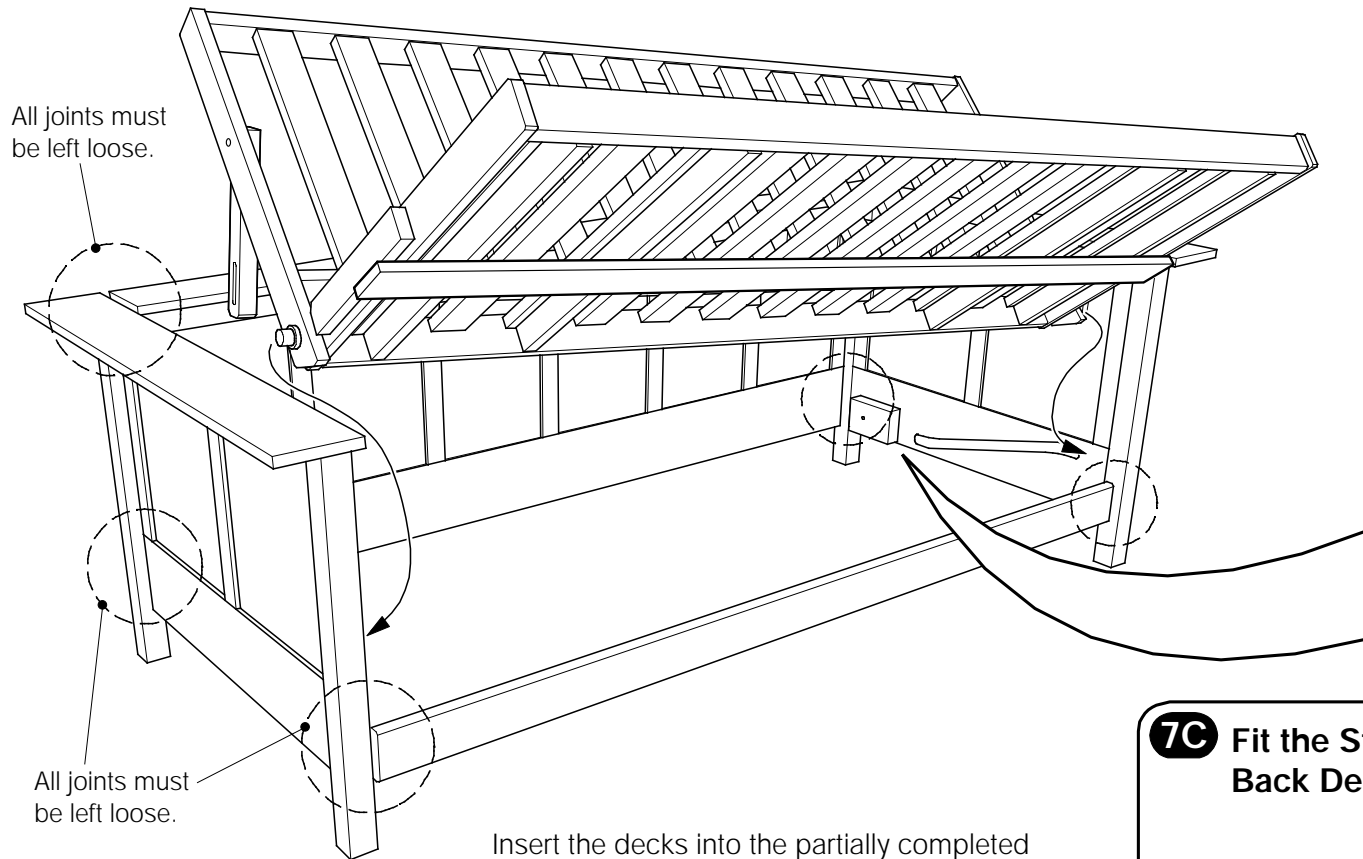

Insert the decks into the partially completed frame. This is where a helper may be useful. When the guides are in the grooves in the Arms, slide the assembly to the back of the frame.

Tighten all Stretcher and Back Panel Bolts.

7B Connect the Advance Arms to the Arms.

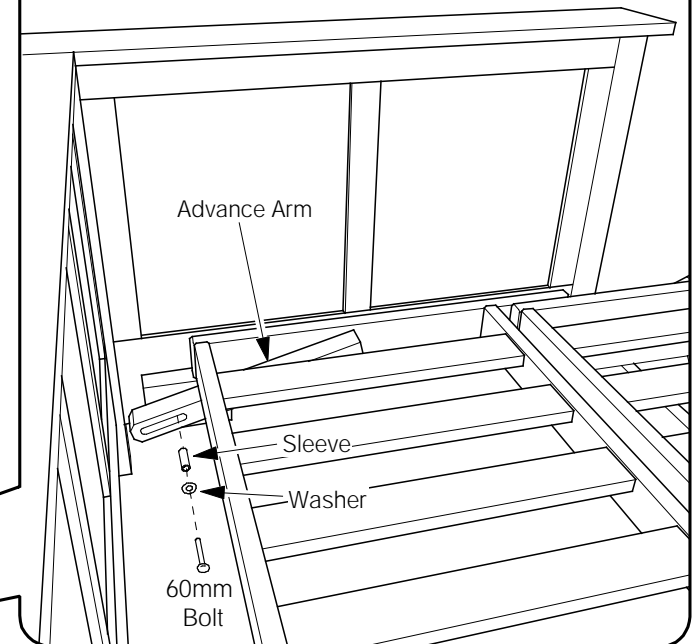

7C Fit the Strap to the Back Deck.

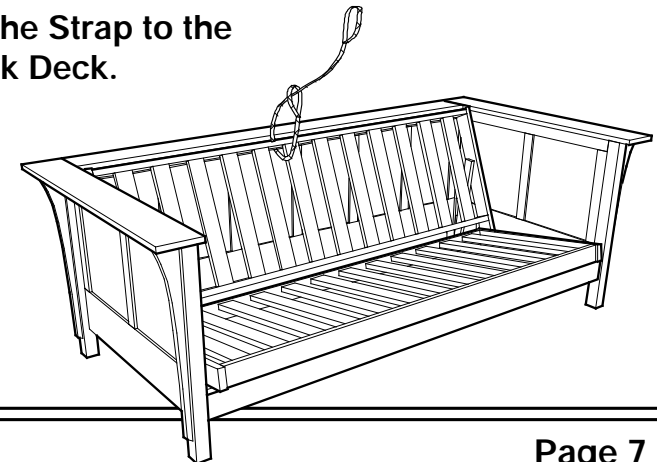

8A Attach the Corbels to the Arms.

Fit the dowel at the top of the Corbel into the hole on the underside of the Arm, and then fit the other dowel into the side of the Arm.

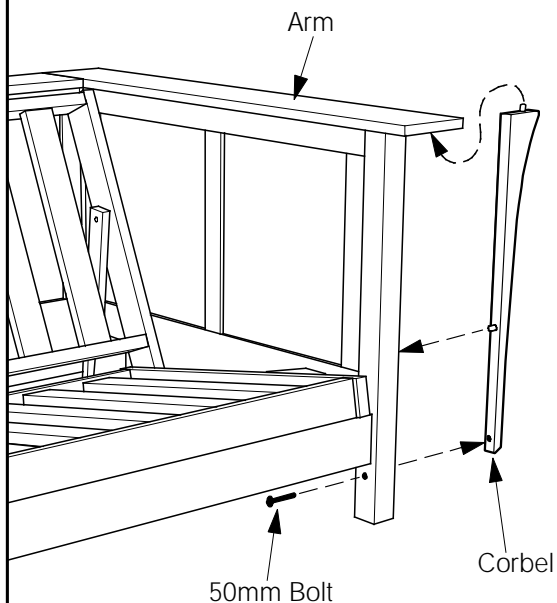

Secure with a short Bolt (50mm) from the inside of the Arm at the bottom. Tighten until the Corbel is snug.

Note:
*Never lift the frame by the arm caps -
 Always lift from the bottom of the arms.*

Operating Instructions: *To convert into couch position:*

- Remove any pillows and other obstructions. Reach to the back and lay the strap on top of the mattress.
- Lift up the seat deck into a vertical position.
- Resting seat deck on your hip, push the foot connector down all the way so that the foot connector touches the side rail - *It is Very Important* that the feet are in proper position - see diagram.



- With one hand lightly push the seat deck down and with other hand pull the back using the Strap, making sure that the mattress clears back rail. Push the seat deck in all the way.
- **DO NOT FORCE** - the frame should operate easily.

Operating Instructions: *To convert into bed position:*

- Lift up the seat deck into a vertical position.
- Resting seat deck on your hip, rotate the foot connector towards you until the feet are fully extended.
- Set the frame down gently.