

S t r a t a F u r n i t u r e
Orion

OR 0903

1A Parts in the Arm Box:

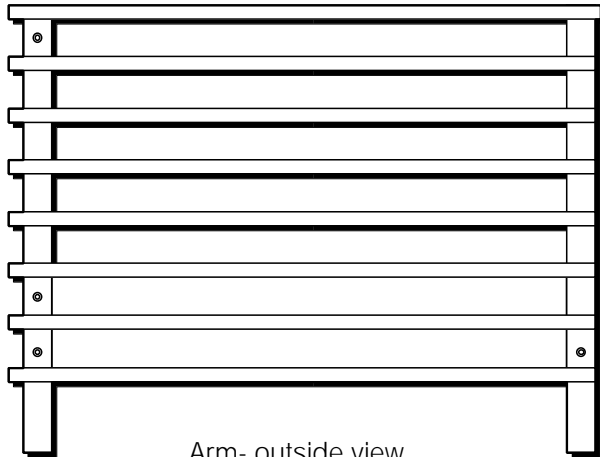

Arm- outside view

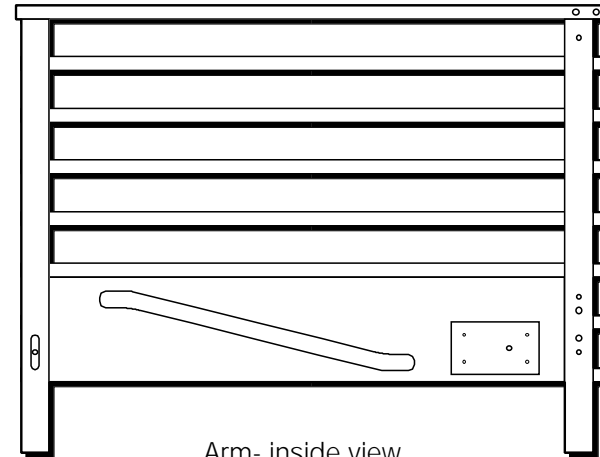

Arm- inside view

1B Parts in the Body Box:

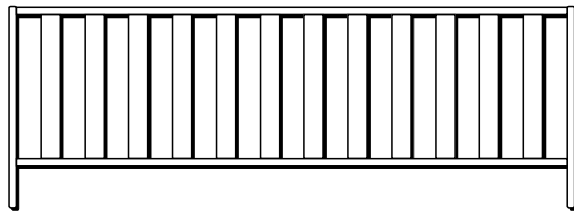

Back Deck **x 1**

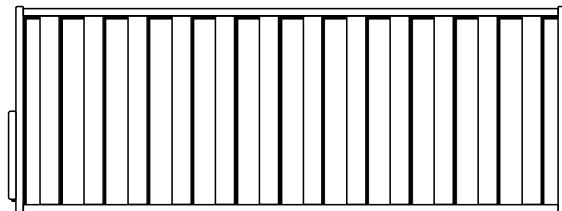

Seat Deck **x 1**
with the Feet attached

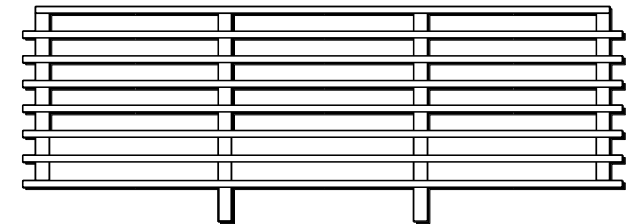

Back Panel **x 1**

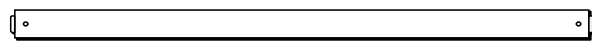

Stretcher **x 1**



Foot Connector Bar **x 1**

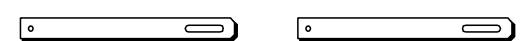

Advance Arms **x 2**

S t r a t a F u r n i t u r e
Orion

OR 0905

2A Hardware in this Box:

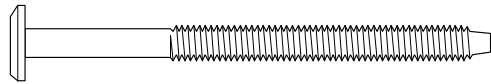

Long Bolts (80mm) **x 2**
For the Stretcher

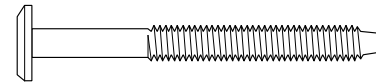

Short Bolts (60mm) **x 12**
*For the Back Panel,
 Advance Arms and
 Foot Connector Bar*



Thumb Nuts **x 2**
 Patent No.: US 6,457,923

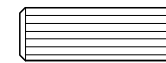

Wooden Dowels
x 6

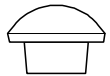

Wood Button
x 10

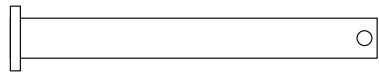

Long Clevis Pins
x 2

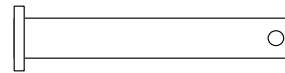

Short Clevis Pins
x 2

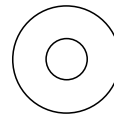

Washers
x 8



Locking Pins
x 4

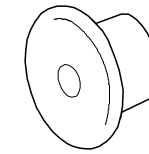

Plastic Runner
x 2

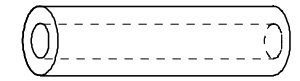

Sleeve
x 2

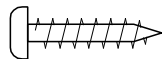

Screw
x 4

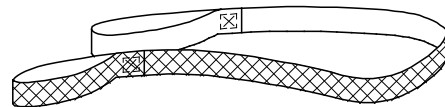

Strap
x 1



Bungies
x 2

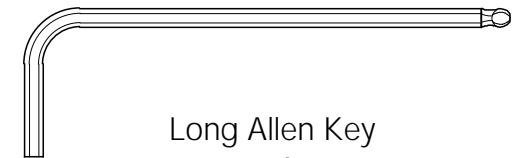

Long Allen Key
x 1

3A Fit Wooden Dowels into the Back Panel.

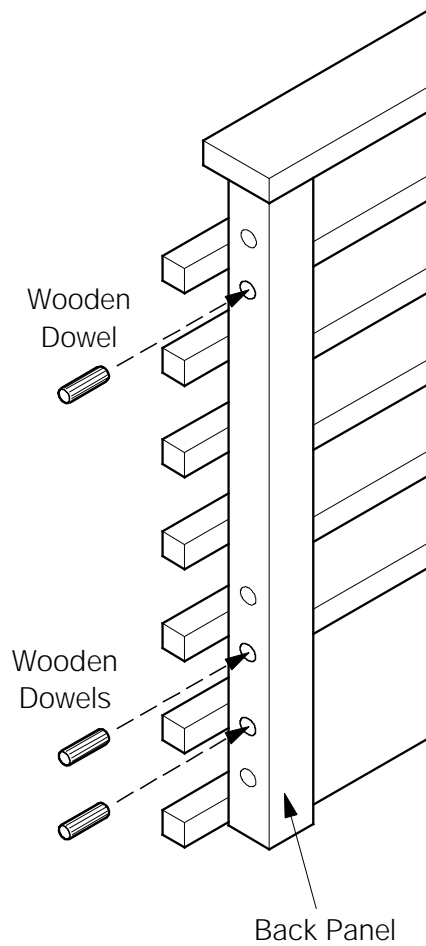

3B Assemble the Back Panel between the Arms.

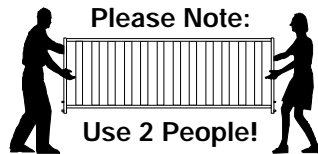
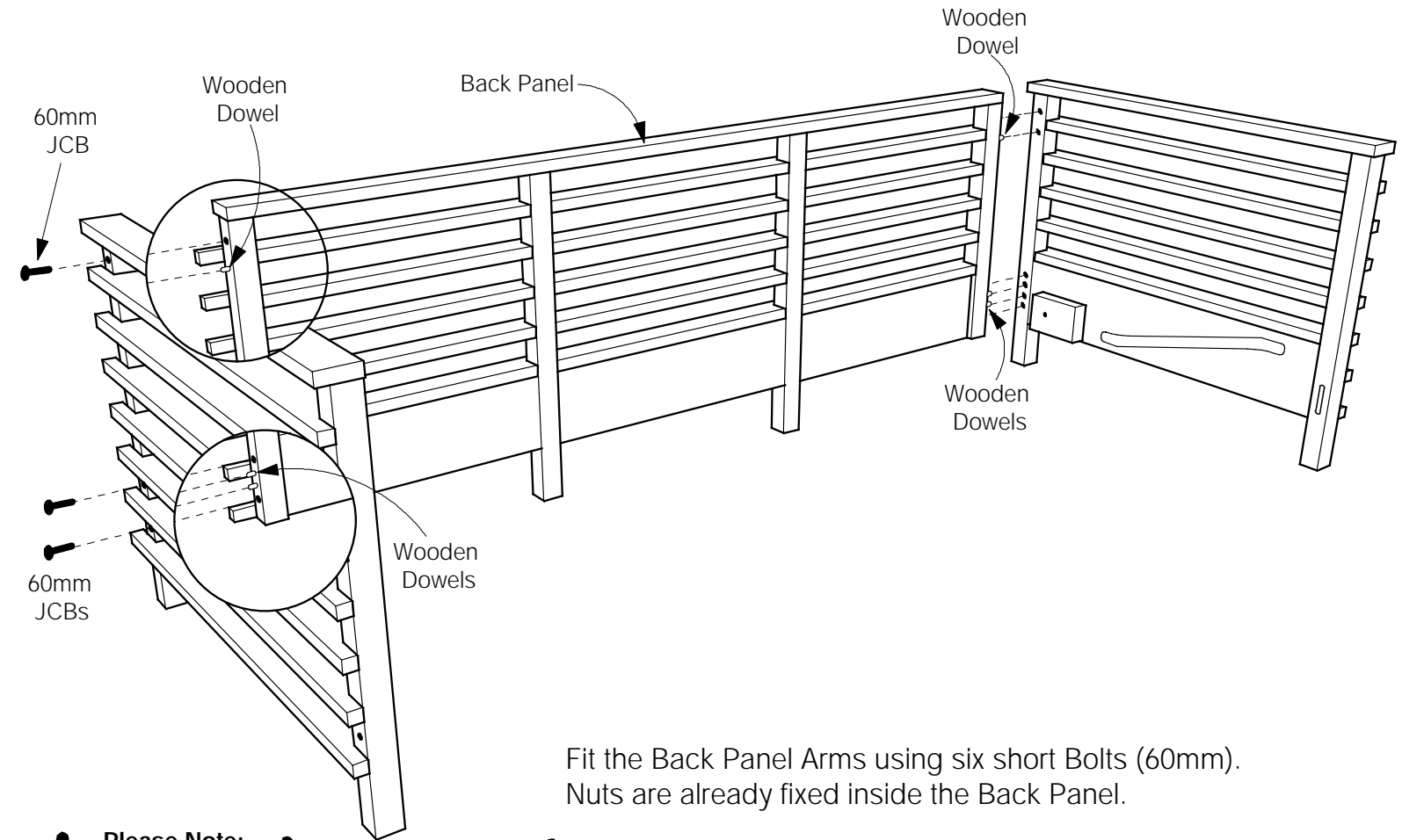

Fit the Back Panel Arms using six short Bolts (60mm). Nuts are already fixed inside the Back Panel.

- ✓ It is helpful to keep the frame squared.
- ✓ It is important that these bolts are left loose!

Strata Furniture
Orion

OR 1103

4A Assemble the Stretcher between the Arms.

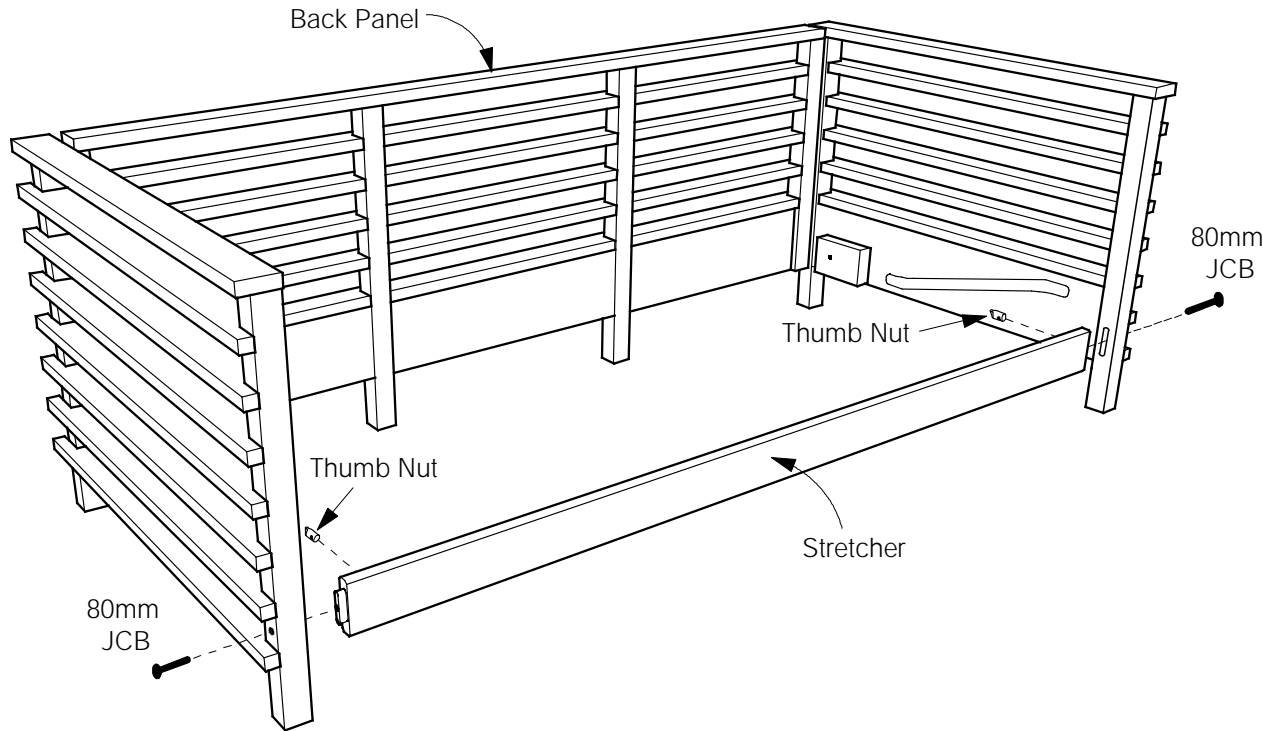

Fit the Stretcher between the Arms. Bolt the parts together with two long Bolts (80mm) and Thumb Nuts.

Drive the Bolts in until they just catch the Nuts.

✓ It is important that these bolts are left loose!

4B Attach the Advance Arms to the Arms

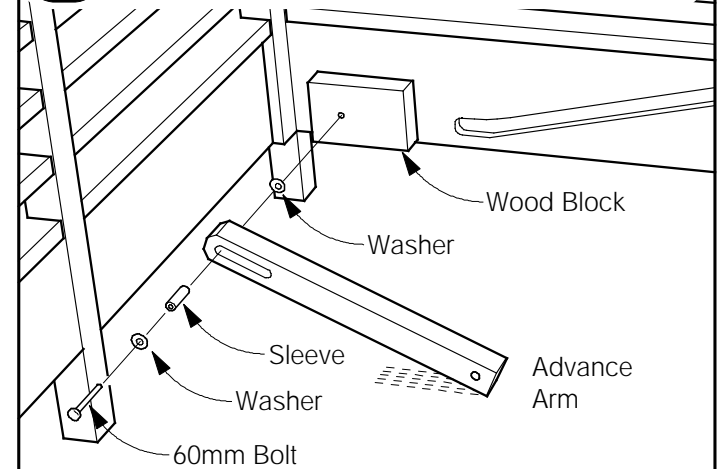

The slotted end of the Advance Arm attaches to the little wood block at the back of the Arm. Slip a washer and Sleeve over the Bolt, and pass it through the slot. Add another washer and fix it to the Arm. Tighten the Bolt. Be sure that the Advance Arm moves freely. Rotate the Advance Arm so that is pointing up.

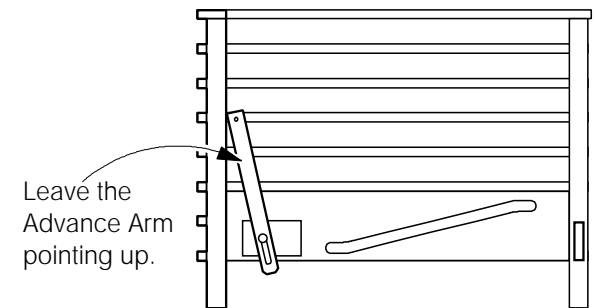

S t r a t a F u r n i t u r e
Orion

OR 0903

5A Assemble the Bungies under the Seat Deck.

Lay the Seat Deck sticker-side down.

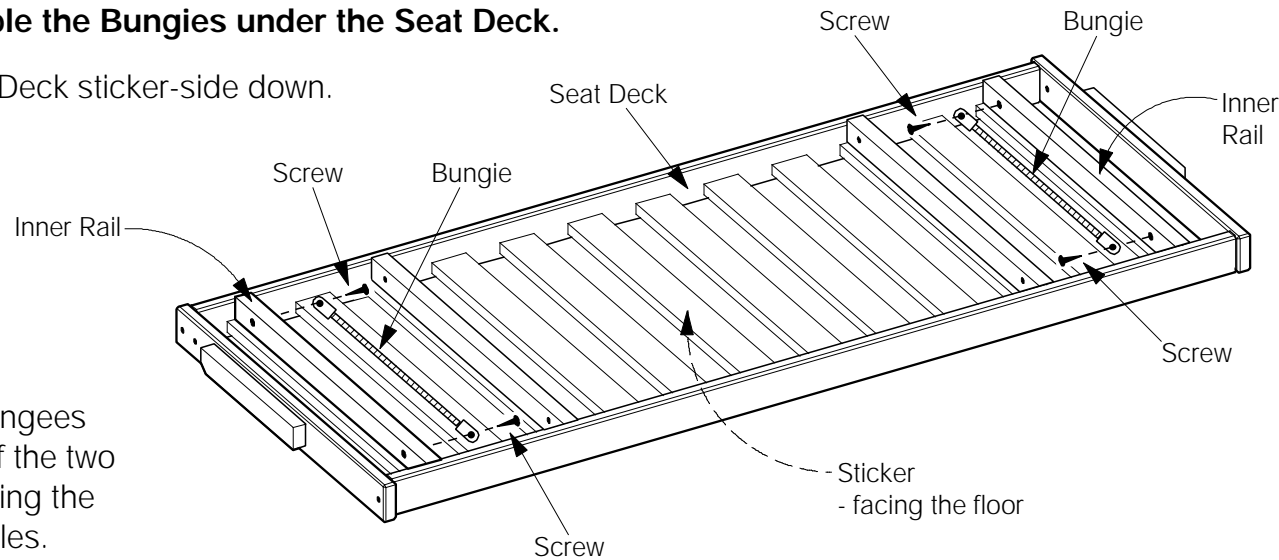

Screw the Bungees to the side of the two inner rails, using the pre-drilled holes.

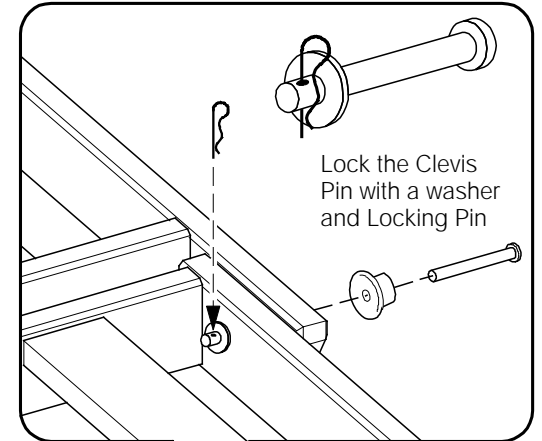

5B Join the Seat and Back Decks together.

Lay both Decks out flat on the floor with the stickers facing upwards.

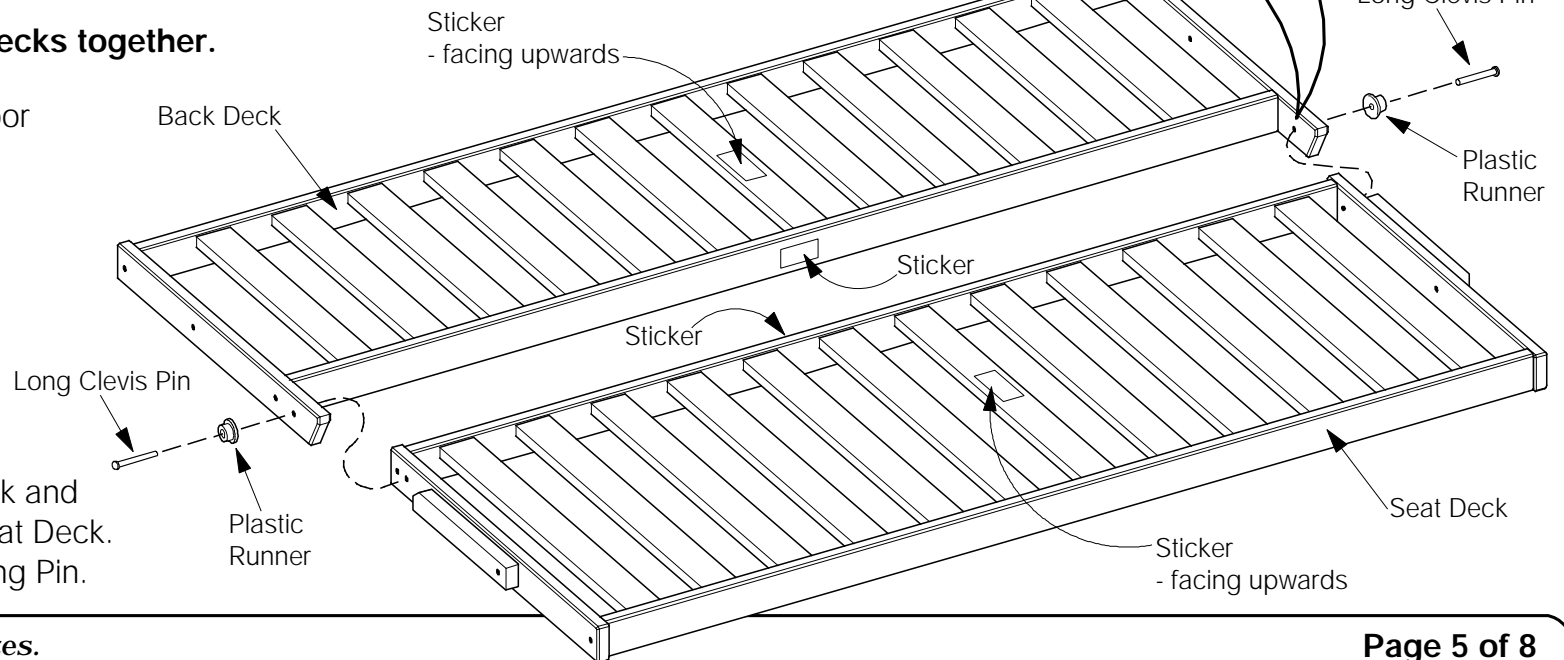

The Seat Deck fits inside the Back Deck as shown. Slip the Long Clevis Pin through the small end of the Plastic Runner, through the hole in the Back Deck and the corresponding hole in the Seat Deck. Secure with a Washer and Locking Pin.

S t r a t a F u r n i t u r e
Orion

OR 0903

6A Fit the Seat and Back Decks to the Frame.

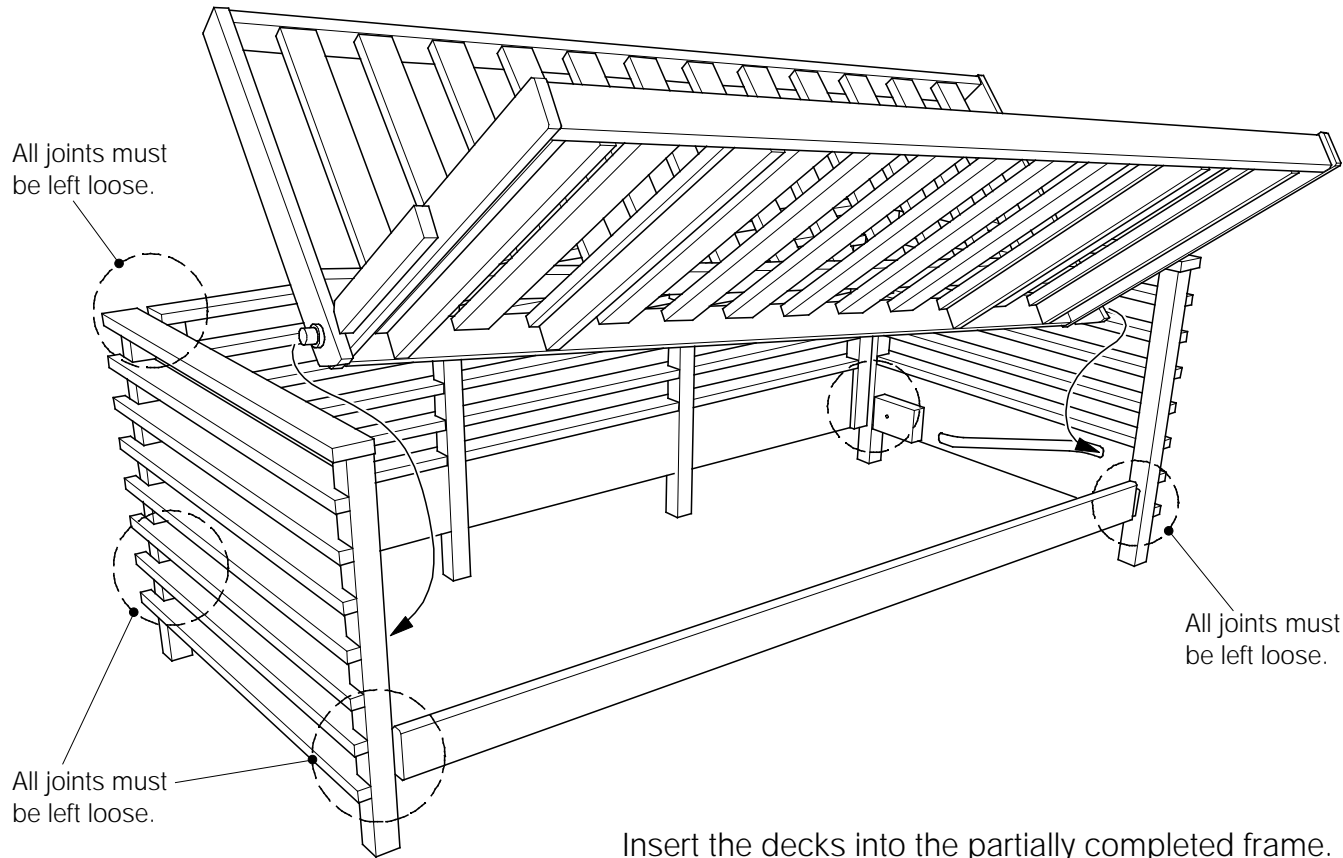

Insert the decks into the partially completed frame. This is where a helper may be useful.

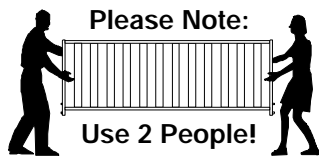

When the guides are in the grooves in the Arms, slide the assembly to the back of the frame.

Tighten all Stretcher and Back Panel Bolts.

6B Connect the Advance Arms to the Back Deck.

Carefully pass a Short Clevis Pin through the Arm into the Hole in the Back Deck. Align with the hole in the Advance Arm, and join them together.

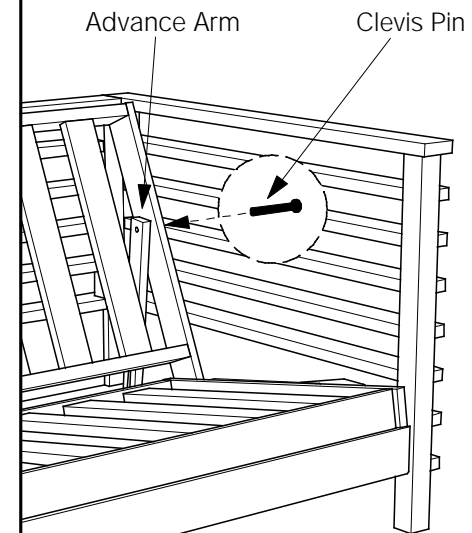

Secure with a Washer and Locking Pin.

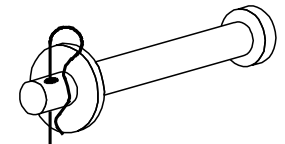

S t r a t a F u r n i t u r e
Orion

OR 0905

7A Attach the Connector Bar to the Legs.

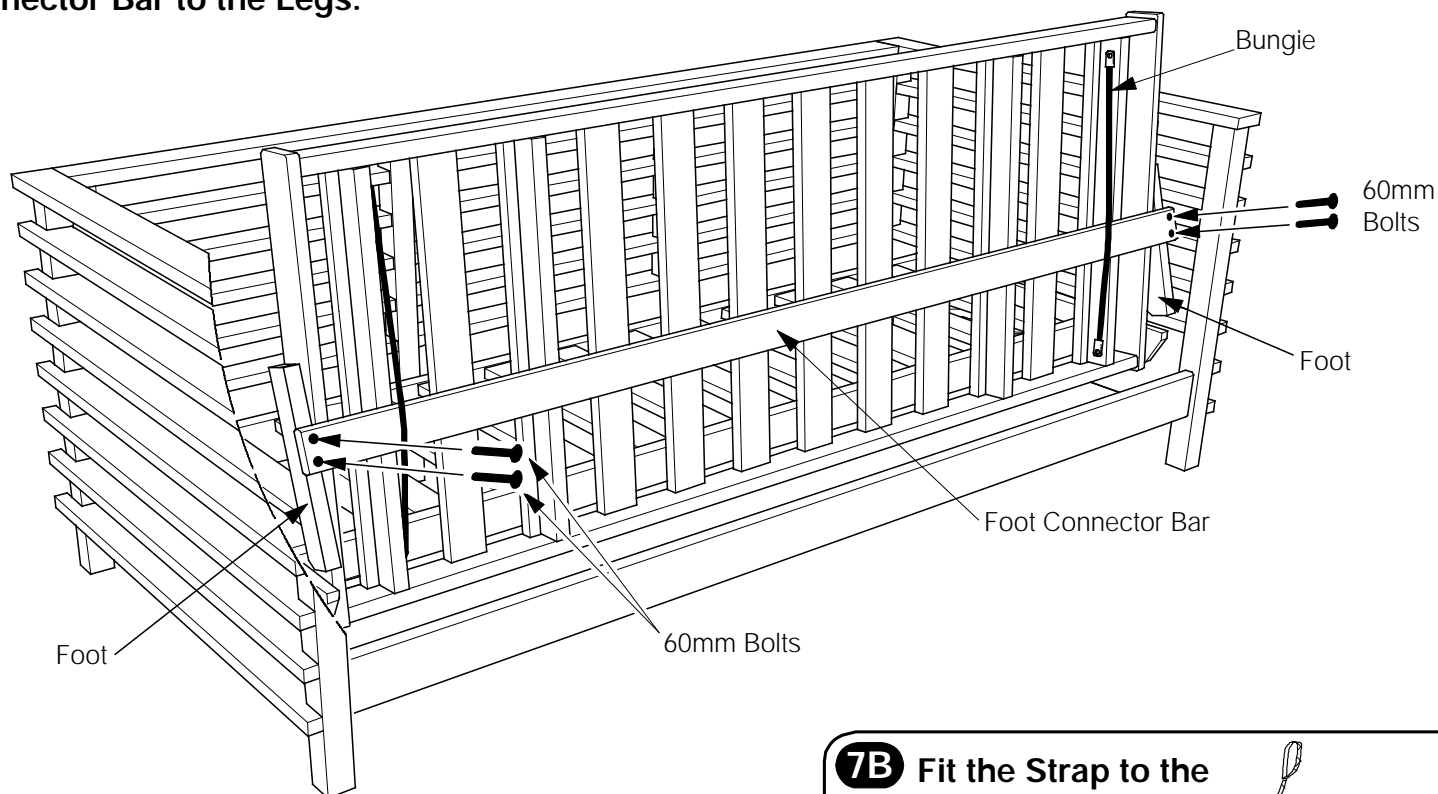

Pull the Seat Deck out to the front of the frame and flip it up. The feet should be pointing downwards.

Work the Foot Connector Bar under the Bungees, and line up the holes between the Connector Bar and the Legs. Make sure the recess for the head of the Bolt is facing outwards.

Use four short Bolts (60mm) and bolt it in place.

7B Fit the Strap to the Back Deck.

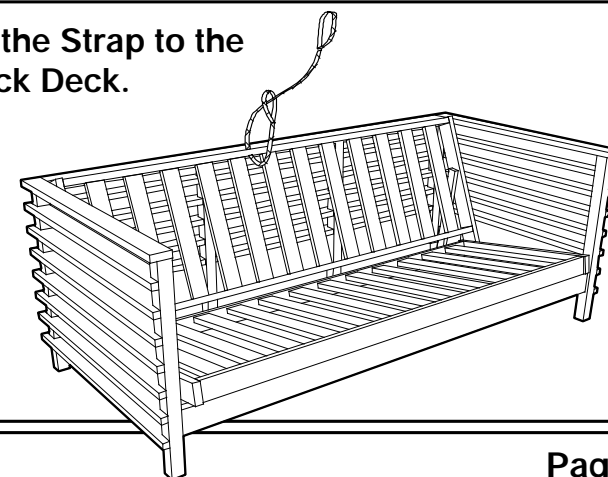

S t r a t a F u r n i t u r e
Orion

OR 0905

8A Fit the Wood Buttons to the Arms.

Finally, when the frame is fully assembled, make sure all the bolts are secure.

Push fit or lightly tap the Wood Buttons into the bolt holes on the Arms & Back Panel.

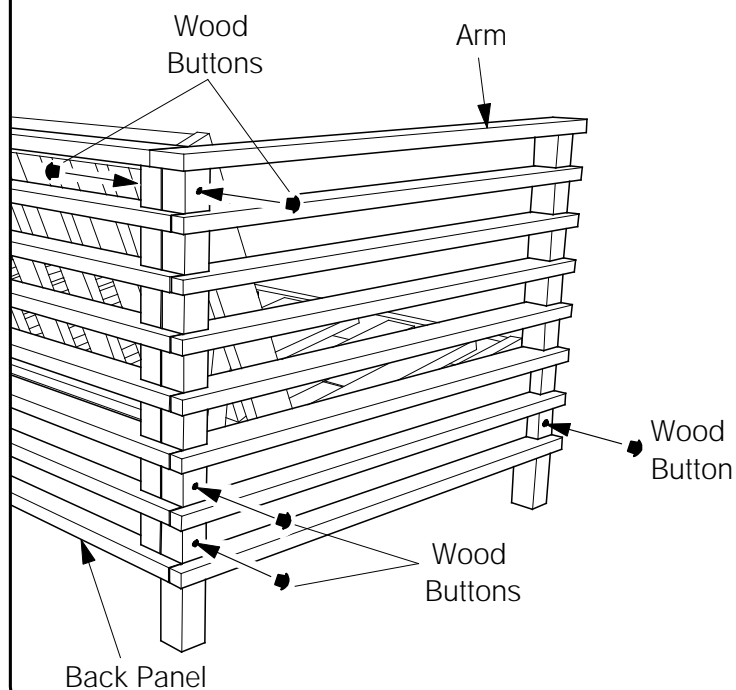

Note:

**Never lift the frame by the arm caps -
 Always lift from the bottom of the arms.**

Operating Instructions: To convert into couch position:

- Remove any pillows and other obstructions. Reach to the back and lay the strap on top of the mattress.
- Lift up the seat deck into a vertical position.
- Resting seat deck on your hip, push the foot connector down all the way so that the foot connector touches the side rail - *It is Very Important* that the feet are in proper position - see diagram.



- With one hand lightly push the seat deck down and with other hand pull the back using the Strap, making sure that the mattress clears back rail. Push the seat deck in all the way.
- **DO NOT FORCE** - the frame should operate easily.

Operating Instructions: To convert into bed position:

- Lift up the seat deck into a vertical position.
- Resting seat deck on your hip, rotate the foot connector towards you until the feet are fully extended.
- Set the frame down gently.